



Society of Cable
Telecommunications
Engineers

SCTE Implication Paper

Deploying Enhanced Media Services with MoCA

The Challenges and Rewards of MoCA Deployment for the Home Network

An Implication paper prepared for the
Society of Cable Telecommunications Engineers
By Spirent Communications



SCTE professional development
develop. advance. lead.

Contents

Deploying Enhanced Media Services with MoCA®	3
Overview	3
A Survey of In-Home Networking Standards	5
HomePNA	5
Powerline (HomePlug).....	6
HomePlug 1.0.....	6
HomePlug AV	6
Ethernet.....	6
802.11b/g.....	7
802.11n.....	7
G.hn (HomeGrid)	7
MoCA	9
MoCA Topologies	9
MoCA PHY Layer.....	10
MoCA MAC Layer.....	10
MoCA QoS	11
MoCA Link Privacy.....	11
Enabling Standards to Support Service Platforms	11
Looking forward	12
Supporting in-home MoCA networks.....	12
Infrastructure	13
Spectrum.....	13
Quality of experience.....	13
Service support	13
Challenges	13
RF meter spectrum limitations	13
CPE statistics limitations	14
Identifying the problem source.....	14
Swapping out components.....	14
Troubleshooting	14
Inter-node throughput test.....	15
CPE output test.....	17
Coax integrity test.....	17
Interference test.....	18
Service testing for DVR sharing.....	19
Troubleshooting steps for inline IPTV video testing.....	20
Conclusion	21
Bibliography	22
Appendix A: Troubleshooting Guide	23
Appendix B: Acronyms	26

Overview

The huge market potential and competition for enhanced video services revenue has MSOs and telcos scrambling for technology and operational advantages. Although billions of dollars have been invested to refurbish and build the network infrastructure to compete and win this lucrative service bundle, there remains uncharted territory for the outside plant and in-home workforce. New video services, including digital video recorder (DVR) sharing and other multimedia sharing, require a network with guaranteed throughput to deliver a positive customer experience. The in-home network is the final and critical piece of the picture. It is currently undergoing a technology transformation to support enhanced service bundles.

The in-home network has generally been viewed as the customer's responsibility. To establish customer loyalty while increasing revenue, service providers must quickly and efficiently correct any problems that surface inside the home. Service turn-up, maintenance, and up-sell capabilities must be done right the first time to avoid costly repeat visits and potential customer churn.

In the next decade, consumer video electronics with embedded Internet and IP video support will be widely available. The Diffusion Group (TDG) anticipates that by 2020 there will be 3.6 billion non-portable network-enabled video nodes in homes worldwide, and over 5 billion by 2030.¹ According to Infonetics research, the total market for residential voice, video, and data services will exceed \$300 billion by 2013.²

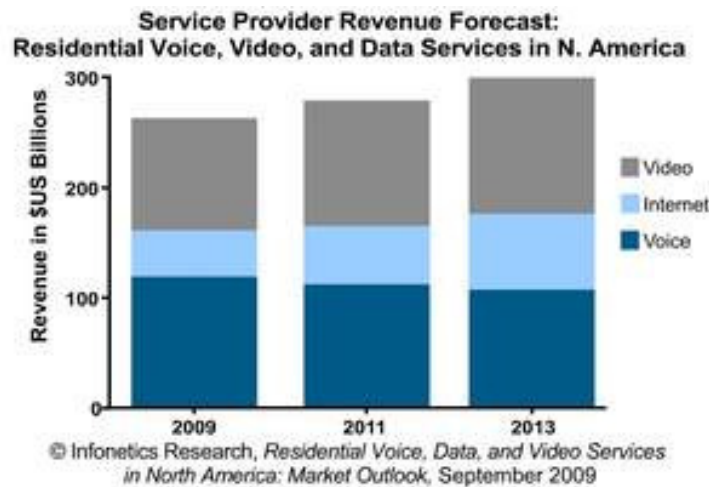

Figure 1. Service Provider Revenue Forecast

According to TDG, the number of homes worldwide with broadband video service will almost triple between 2010 and 2030, from 440 million to 1.2 billion. In the same period, the number of in-home networks that are broadband enabled will increase by almost 7 times, from 150 million to over 1 billion.

¹ Deans, David H. "Video-Enabled Home Network Node Growth." Digital Lifescapes. Mar. 20, 2009 <<http://dhdeans.blogspot.com/2009/03/video-enabled-home-network-node-growth.html>>

² "Wi-Fi, MoCA, HPNA, and HomePlug - who will win?" Oct. 24, 2006 <<http://www.tvover.net/2006/10/24/WiFi+MoCA+HPNA+And+HomePlug+Who+Will+Win.aspx>>

This represents a 250 percent increase in penetration of broadband-enabled home networks, from 34 percent to 83 percent.³

The “build out” of the in-home physical plant is the final element left unaddressed in the development of the end-to-end network of the past decade. This infrastructure enables service providers to deliver more sophisticated, and lucrative, video services.

The open question is – which in-home networking technology will best support the requirements for advanced services and how will this technology affect current field operations? A number of technologies with overlapping functionality compete for mind share in the in-home network market. These include traditional technologies such as 10/100 Ethernet and WiFi, and several new contenders designed more specifically to support broadband video services – MoCA, HPNA, HomePlug, 802.11N, and G.hn.

By 2011, three technologies for in-home broadband networking (MoCA, HPNA and HomePlug) will ship a combined 45 million connections on set-top boxes (STB) and residential gateways, according to ABI research.⁴

It's clear that DVR sharing is the primary driver in the strategic move to extend the service network beyond the traditional demarcation point into the home. By offering DVR sharing, MSOs increase revenue, reduce costs (as opposed to installing multiple DVRs in a home) and decrease customer churn. But this move is not without risk. MSOs must select the right technology for in-home networking to guarantee customer satisfaction while creating a solution that is sustainable in terms of support and maintenance. In this highly competitive environment, the MSOs must truly get it right the first time.

Several key issues must be considered when selecting an in-home networking technology:

- Infrastructure: Use existing wiring in the home (coax, twisted pair, and power), install new wiring (CAT5/6) or go wireless?
- Spectrum: Cable TV (CATV) uses the spectrum 5–1000 MHz. Solutions over coax must take this into consideration.
- Quality of experience (QoE): To satisfy consumer expectations, the solution must deliver dedicated bandwidth for video with no interference from other (possibly high-bandwidth) traffic, such as gaming or file transfers.
- Service support: In-home troubleshooting is no longer simply measuring the broadcast RF video signal with a signal level meter (SLM). Troubleshooting the problem now requires additional capabilities and expertise.

MoCA has taken a commanding lead as the technology of choice for MSOs rolling out DVR sharing and other multimedia services. The technology operates on coax installations in over 90 percent of US homes. But the technology will only benefit an MSO if data throughput can support multi-room DVR sharing and other multimedia sharing applications.

³ Deans, David H. “Video-Enabled Home Network Node Growth.” Digital Lifescapes. Mar. 20, 2009
<<http://dhdeans.blogspot.com/2009/03/video-enabled-home-network-node-growth.html>>

⁴ “Wi-Fi, MoCA, HPNA, and HomePlug - who will win?” Oct. 24, 2006
<<http://www.tvover.net/2006/10/24/WiFi+MoCA+HPNA+And+HomePlug+Who+Will+Win.aspx>>

This paper begins with a detailed survey of the standards available for in-home networking and continues with a closer review of the MoCA specifications. It discusses the challenges inherent in supporting a commercial MoCA in-home network and provides guidelines for troubleshooting and problem resolution with a view to increasing customer satisfaction and reducing support costs.

A Survey of In-Home Networking Standards

HomePNA

HomePNA is a consortium of technology organizations that has developed a series of recommendations for transporting multiplay services and multimedia content over the cable plants located in consumer residences. HomePNA technology has been widely deployed primarily by telcos in the North American market who have leveraged the recommendation to deliver IPTV and multi-room entertainment services to consumers.

A number of the recommendations authored by the members of the HomePNA have been adopted and standardized by the ITU-T. The most recent recommendation, HomePNA 3.1 (ITU-T G.9954), specifies a home networking protocol with a physical layer that supports transmitting and receiving frames using quadrature amplitude modulation (QAM)⁵ over twisted-pair wiring or coaxial cabling. The twisted-pair physical layer specification defines two frequency ranges, 4–20 MHz and 12–28 MHz, with QAM constellation sizes between 2–10 bits per symbol and data rates from 4–160 Mb/s. The coaxial cabling physical layer specification, by contrast, specifies four frequency ranges between 4–52 MHz, QAM constellation sizes between 2–10 bits per symbol and data rates between 4–320 Mb/s. Though the HomePNA 3.1 physical layer recommendation assures interoperability with ADSL, VDSL and other services operating below 12 MHz, HomePNA 3.1 will not support sharing the cable plant with VDSL services using profiles above 12 MHz and cable television services using the 5–42 MHz and 5–65 MHz return paths.

The HomePNA 3.1 media access control (MAC) layer is based on a carrier sense multiple access with collision avoidance (CSMA/CA) architecture.⁶ A device is assigned the master role. The master node controls media access by planning device transmit times and advertising the plan to the other nodes. The nodes synchronize to the media access plan and time transmissions accordingly. The master node also has responsibility for network admission and security, which is based on shared-key encryption. Notably, the HomePNA 3.1 MAC layer also includes two techniques for differentiating the quality of service (QoS) offered by the network—one technique based on priority and another technique that allocates capacity to unidirectional flows based on a service profile.

⁵ QAM is a modulation scheme that conveys two signals or bit streams by changing the amplitudes of two carrier waves. These two waves are out of phase with each other by 90 degrees and are thus called quadrature carriers — hence the name of the scheme.

⁶ CSMA/CA is a media access control protocol that verifies the absence of other traffic before transmitting on a shared transmission medium, such as an electrical bus, or a band of the electromagnetic spectrum. If the channel is sensed busy before transmission then the transmission is deferred for a random interval. This reduces the probability of collisions on the channel.

Powerline (HomePlug)

The HomePlug Powerline Alliance is a trade association that has developed a series of specifications that define how residential electrical wiring may be leveraged to transport voice, video and data services between networked devices in a home. Generally, HomePlug is deployed throughout the European Union, telcos being the leading adopters. In the North American market, however, there is not a significant installed HomePlug base as MSOs have elected to leverage existing in-home coaxial cabling to transport multimedia content. The primary applications to date for HomePlug technologies are residential IPTV and other multimedia content. Two specifications targeting in-home networking have been released by the HomePlug Powerline Alliance.

HomePlug 1.0

HomePlug 1.0 was published June 2001 and defined a physical layer based on orthogonal frequency division multiplexing (OFDM)⁷ operating at 14 Mb/s and using the frequency band 4.5–21 MHz. Eighty-four equally spaced, discrete differential binary phase-shift keying/differential quadrature phase-shift keying (DBPSK/DQPSK)⁸ modulated carriers transport the bit stream. The physical layer requires forward error correction (FEC) and interleaving. The MAC layer is based on a CSMA/CA architecture that is enhanced to accommodate the noise and interference characteristics of the media and to guarantee QoS to multimedia applications. HomePlug 1.0 uses shared-key 56-bit DES encryption for security.

HomePlug AV

Targeting the ability to transport multiple in-home multimedia streams, the HomePlug AV specification significantly increased the theoretical maximum physical layer data rate to 200 Mb/s. This was accomplished by allowing adaptive modulation (BPSK–1024 QAM) over a maximum of 1,155 OFDM sub-carriers occupying the frequency range 2–28 MHz. Additional enhancements include a MAC layer based on both time division multiple access (TDMA)⁹ and CSMA/CA architectures and security based on 128-bit AES encryption and dynamic key generation and exchange.

Ethernet

Originally developed by Xerox Palo Alto Research Center in the late 1970s and standardized by IEEE 802.3 in the early 1980s, Ethernet has become the predominant local area networking technology for enabling data communications and recently has evolved to be the technology of choice for transporting voice, video and data traffic over metropolitan and wide area networks. The 802.3 family of standards includes specifications for Ethernet operating at 10 Mb/s – 100 Gb/s over a range of media types.

⁷ OFDM is a frequency-division multiplexing scheme utilized as a digital multi-carrier modulation method. A large number of closely-spaced orthogonal sub-carriers are used to carry data. The data is divided into several parallel data streams or channels, one for each sub-carrier. Each sub-carrier is modulated with a conventional modulation scheme (such as quadrature amplitude modulation or phase shift keying) at a low symbol rate, maintaining total data rates similar to conventional single-carrier modulation schemes in the same bandwidth.

⁸ DPSK is a digital modulation scheme that conveys data by changing the phase of a carrier signal over a finite number of phases, each assigned a unique bit pattern. In modulation, the bit pattern is used to change the phase of the wave by a specified amount. The demodulator determines the changes in the phase of the received signal. DBPSK uses two phases separated by 180 degrees. DQPSK uses four points on a constellation diagram, equispaced around a circle.

⁹ TDMA is a channel access method for shared medium networks. It allows several users to share the same frequency channel by dividing the signal into different time slots. The users transmit in rapid succession, one after the other, each using reserved time slots. This allows multiple stations to share the same transmission medium, such as a radio frequency channel, while using only a part of its channel capacity.

Residential networks have principally used 10/100 Ethernet over twisted pair to communicate between hosts in the home. Traditionally, residential Ethernet has supported data communications between personal computers and the Internet, though increasingly home Ethernet networks are used to deliver voice and video over IP, gaming and other applications for the entire range of consumer electronics in the home.

802.11b/g

The IEEE 802.11 standard provides a specification for transporting information over the unregulated 2.4 GHz and 5 GHz frequency bands. Two amendments to the 802.11 standard, 802.11b and 802.11g, have become the most commonly utilized wireless networking technologies. The 802.11b amendment uses direct sequence spread spectrum modulation at 11 Mb/s over the 2.4 GHz band with a maximum indoor range around 100 feet and a maximum outdoor range around 300 feet. 802.11g provides the same coverage, but the physical layer is enhanced to use OFDM, which increases the maximum supported rate to 54 Mb/s. Both 802.11b and 802.11g operate on 22 MHz channels and use CSMA/CA. All 802.11g capable devices are backward-compatible and interoperable with devices supporting 802.11b.

The 802.11b/g networks are deployed globally, particularly for residential networks to connect personal computers and access the Internet. The performance of 802.11b/g networks, however, is significantly degraded in areas with many base stations using the same channels, or due to interference from other equipment (e.g. cordless phones, security systems, remote sensors) operating in the 2.4 GHz band. Additionally, the actual throughput offered by 802.11b/g networks is insufficient to transport high-bandwidth multimedia content. This has driven the telecommunications industry to develop new wireless local area networking technologies

802.11n

802.11n promises to significantly enhance the throughput and coverage of 802.11 wireless networks. Ratified by the IEEE during September 2009, 802.11n also operates over the 2.4 MHz and 5 MHz frequency bands and specifies maximum physical layer bit rates reaching 600 Mb/s and MAC layer throughput exceeding 100 Mb/s. Many consumer electronics manufacturers and service providers globally plan to use the data rate enhancements to transport multimedia content between residential gateways, STBs, gaming equipment, personal computers and other consumer devices connected to home networks.

A number of technical advancements in 802.11n permit improved performance. The physical layer supports Multiple Input Multiple Output (MIMO) signal processing and spatial multiplexing, which increases data rates significantly while improving signal-to-noise ratios. Additionally, the MAC layer supports frame aggregation, which allows multiple frames to be combined and transported using one data unit, thereby reducing transport header overhead. The MAC layer also includes a block acknowledgment mechanism, which increases the efficiency of the MAC layer significantly. Finally, 802.11n supports channel bonding, which allows two adjacent 20 MHz channels to be combined into a single 40 MHz channel, effectively doubling the transmission capacity.

G.hn (HomeGrid)

G.hn describes the ITU-T standardization effort tasked with developing a universal next-generation home networking transceiver that operates at gigabit-per-second data rates over all three primary types of residential cable plants—electrical wiring, twisted pair and coaxial cabling. The study group's first

recommendation, G.9660, was approved in December 2008 and specifies the G.hn physical layer and systems architecture. The full G.hn recommendation, including the G.hn MAC layer and security architecture, has reached the ITU-T baseline text stage and likely will be approved in the coming months.

The primary goal of the G.hn standard is to transport multimedia content between devices connected to the home network. Consumer electronics, including televisions, STBs, residential gateways, and personal computers have been targeted for G.hn support. Additional G.hn applications will include home automation and a range of smart grid features, including energy demand management and others. G.hn chipset availability is expected during 2010 and G.hn capable devices are projected to become available in the 2010–2011 timeframe. A number of technology organizations established the HomeGrid Forum to promote G.hn standardization and encourage the industry to adopt the G.hn specifications.

Notably, the G.hn specifications do not offer backward compatibility with either MoCA or HomePlug networks. Many North American and European operators have deployed MoCA or HomePlug networks widely and do not envision migrating to G.hn without support for these existing home networking standards.

The G.hn specification includes a physical layer that uses OFDM to divide traffic over multiple sub-carriers using QAM. The G.hn spectrum usage depends on the physical media type.

Media	Frequency Range	Carrier Spacing
Electrical Wiring	0 – 200 MHz	24.41 kHz
Twisted Pair	0 – 100 MHz	48.42 kHz
Coaxial Cabling	300 – 2000 MHz	193.51 kHz

Table 1. Media frequency range and carrier spacing

The frequency range selected for each physical media type ensures interoperability with current home networking technologies. Additionally, the G.hn specifications provide mechanisms for avoiding noise and other interference. G.hn also provides error recovery and retransmission capabilities using low-density parity-check, FEC and automatic repeat request.

The G.hn MAC layer is based on the TDMA architecture in which a master G.hn node controls admission to the network and schedules transmission opportunities for slave nodes connected to the G.hn domain. The G.hn MAC layer includes mechanisms for reserving link capacity and guaranteeing QoS to specific traffic flows. The G.hn recommendation also supports security using X.1035 authentication and AES-128-based encryption. Bidirectional communication between individual G.hn nodes is secured to assure that other nodes participating in the domain cannot eavesdrop on point-to-point conversations.

Several groups have announced support for the ITU G.hn standard, including the Consumer Electronics Powerline Communication Alliance (CEPCA), HomePNA Alliance, and Universal Powerline Association (UPA). However, HomePlug and MoCA spokespersons have expressed skepticism about widespread adoption of G.hn in North America, centered largely on the lack of backward compatibility with or performance gains over existing deployed standards.

MoCA

The Multimedia over Coax Alliance (MoCA) is an association of consumer electronics retailers and manufacturers, communications services providers, and test and measurement equipment vendors developing and promoting a new standard for home entertainment networks operating over coaxial cabling. The primary goal of MoCA is to develop a high-performance, high-capacity home networking technology suitable for transporting multiple streams of high-definition multimedia content that leverages existing residential coaxial cabling and coexists with the services currently using the cable plant. To this end, the MoCA 1.0 standard supporting 135 Mb/s throughput was approved in December 2005. The MoCA 1.1 standard, which increased throughput to 175 Mb/s, was released in October 2007. MoCA has been widely deployed throughout North America, principally to support video-on-demand services and multi-room DVR.

MoCA Topologies

MoCA operates over the hierarchical (branching tree) physical topology of the home coaxial cable plant. The root is the first passive splitter connected to the service provider's drop cable. Branches flow from secondary splitters and outlets in the home. The maximum cable distance supported between the root and the last outlet is 300 feet and the maximum attenuation permitted is 25 dB. Since the characteristics of the physical paths between various nodes will differ, the MoCA standard specifies a logical, fully-meshed point-to-point network in which each of the nodes establishes a bi-directional connection with all other nodes. The following drawings illustrate the physical and logical MoCA networks.

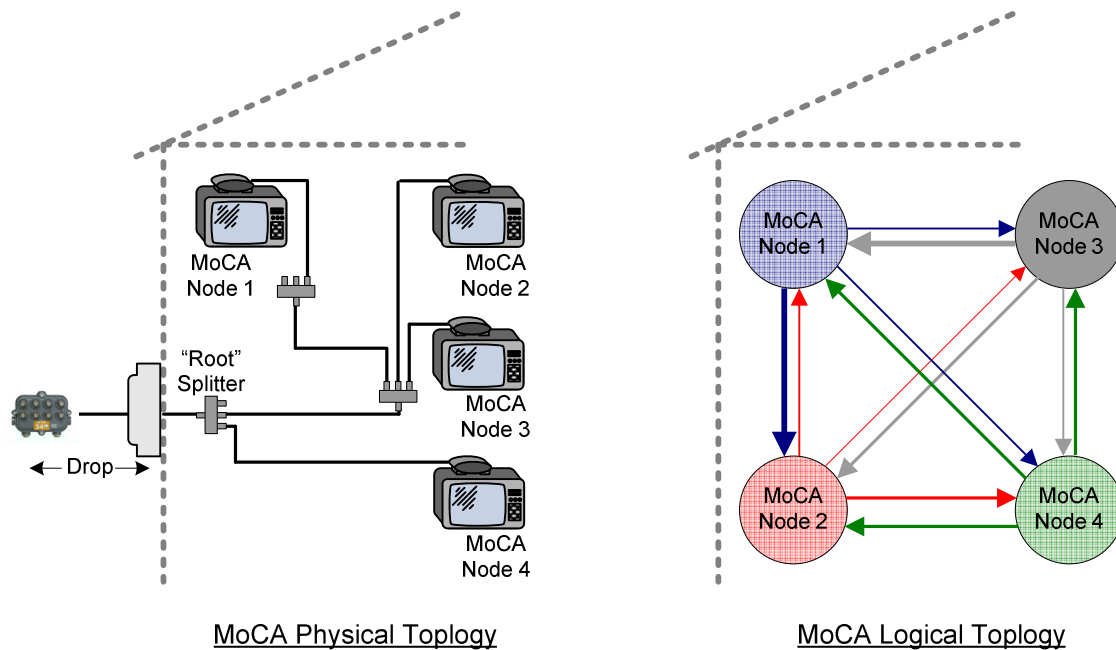

Figure 2. MoCA physical and logical topology

The MoCA 1.0 standard allows eight nodes to communicate using the same network simultaneously while the MoCA 1.1 standard permits a maximum 16 nodes.

MoCA PHY Layer

The MoCA physical layer uses 50 MHz channels located in the spectrum 850–1525 MHz. The MoCA standard organizes the channels into multiple bands across the available spectrum. Only one channel per band is used on a physical network, though multiple MoCA networks may be formed over the same coaxial cable plant using different bands. The drawing below describes the MoCA frequency plan. Note how the frequency plan allows MoCA networks to coexist with CATV services sharing the same cabling. For this reason, additional installation and maintenance procedures must be considered when MoCA is deployed.

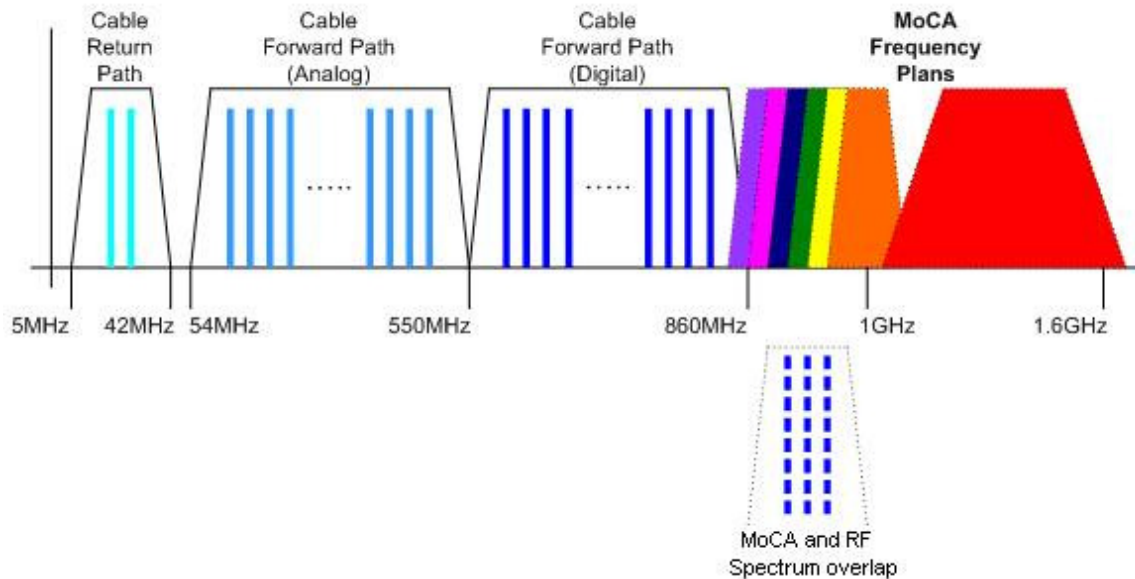

Figure 3. MoCA frequencies

At the physical layer, MoCA uses a technique called adaptive constellation multi-tone (ACMT)—modeled after OFDM—to carry data between nodes. Units of data named ACMT symbols are mapped onto 224 discrete orthogonal sub-carriers that occupy the 50 MHz MoCA channel bandwidth. Each of the sub-carriers is modulated independently using 1–8 bits per symbol (BPSK–256 QAM). The MoCA standard allows the bit loading of each sub-carrier to be controlled based on the physical characteristics of the path between the transmitting and receiving nodes. This is accomplished using probe messages, which are exchanged periodically, to determine the physical characteristics between each pair of MoCA nodes communicating over the network. Based on the probe messages, MoCA nodes are able to develop modulation profiles that specify the bit loading attributes between the nodes. MoCA modulation profiles are designed to optimize throughput between nodes while assuring a low bit error rate. MoCA also provides additional protection using Reed-Solomon FEC. The theoretical maximum physical-layer bit rate is 270 Mb/s.

MoCA MAC Layer

The MoCA standard controls access to the shared MoCA channel using TDMA. Generally, the responsibility for controlling transmissions on the network is assigned dynamically to one MoCA node

designated the network controller (NC). The role of the NC is central to the following MoCA MAC-layer operations:

- **System Time:** Since MAC layer transmissions are based on TDMA, all nodes connected to a MoCA network must share the same clock reference. The NC is the master reference for the network and advertises the time periodically so nodes may synchronize.
- **Node Admission:** After physically connecting to the residential coaxial cabling, MoCA nodes scan through the MoCA channels to discover the available MoCA network or networks. Nodes use beacon messages, which are transmitted periodically by the NC, for discovery. A MoCA node receiving a beacon attempts to join the MoCA network by transmitting an admission request message to the NC. The NC then starts the procedure to admit the node to the network. A number of admission request/response messages are exchanged between the NC and the new node. Following this procedure, the new node is admitted to the MoCA network and permitted to transmit frames.
- **Bandwidth Allocation:** The NC coordinates transmissions on the MoCA network using control messages. Periodically, the NC broadcasts a message that specifies the times during which nodes may request the opportunity to transmit frames. The nodes respond by forwarding bandwidth reservation request messages to the NC. After scheduling transmission opportunities, the NC broadcasts a message that includes a media access plan specifying the times at which MoCA nodes may transmit frames. The MoCA nodes respond by forwarding frames during the assigned time slots.

MoCA QoS

MoCA 1.0 enables QoS for different traffic classes using priority-based queuing. Three traffic classes are supported—high (voice), medium (streaming media) and low (interactive and best effort) priority. The 802.1p field identifies the frames associated with each traffic class.

MoCA 1.1 enhanced the quality of service available over MoCA networks by allowing guaranteed bandwidth reservations for specific unidirectional traffic flows. MoCA 1.1 nodes can transmit to the NC bandwidth reservation request messages, which specify the attributes of the traffic flow—information rate, burst size, packet size and duration. The NC receives the reservation request, coordinates with the other nodes and allocates bandwidth accordingly.

MoCA Link Privacy

The MoCA MAC layer protects access to the network and information exchanged between connected nodes using key-based authentication and encryption. MoCA nodes use a shared password to derive the keys needed to authenticate nodes requesting admission and to encrypt frames. All transmissions are encrypted, excluding the beacons used to admit nodes to the network. MoCA supports the 56-bit DES standard.

Enabling Standards to Support Service Platforms

In addition to the Layer 1 standards discussed in this paper, other standards are being developed to advance interactivity and interoperability of consumer devices. These include the OpenCable™ Application Platform (OCAP™) marketed under the name tru2way®, and the Digital Living Network AllianceSM (DLNA).

OpenCable, managed by CableLabs®, began in 1997 to enable the developers of interactive television services and applications to design products that will run successfully on any cable television system in North America, independent of set-top or television receiver hardware or operating system software choices.

Established in 2003, the goal of DLNA is to create a framework to allow consumers to easily and conveniently acquire, view and manage a variety of digital content on any electronic device and from any location in their home and beyond. More than 240 member companies meet regularly to develop the DLNA Interoperability Guidelines to address growing consumer requirements and incorporate new standards.

Looking forward

MoCA provides an industry and consumer accepted platform for in-home networking with sufficient bandwidth and QoS support to guarantee a high customer QoE. The battle over in-home networking standards is still in the early stages, but with dozens of certified products and an installed user-base of millions of nodes, MoCA is the clear choice for MSOs deploying high-value services. Those numbers will continue to increase as MoCA 2.0 is developed and throughput is significantly increased.

However, MoCA only addresses homes with coax. In addition, since the provider has no control over the in-home physical plant, and the quality of the typical coax installation is uncertain, customer support and troubleshooting problems arise when QoE issues are reported.

The MoCA 2.0 specification is currently under development. It will be backward compatible with MoCA 1.0/1.1. It is targeted to support a PHY rate of 1 Gb/s with a net throughput rate of 400 Mb/s or greater.

The explosion of entertainment services, in-home entertainment networks, and the devices that make them possible will continue for decades to come. The integrity of the in-home coax physical plant, which was, until recently, outside the domain of the providers, poses daunting challenges for those delivering high-bandwidth entertainment services to an in-home network. The ability of field technicians to quickly and accurately pinpoint and correct the source of quality problems has a dramatic impact on product quality, support costs, customer satisfaction, and brand credibility.

These challenges must be addressed with optimized test equipment and a best-practices test methodology. As discussed below, existing SLM field testers have little visibility to the MoCA frequency spectrum and network operation. It's very possible for existing broadcast video to function correctly while DVR sharing experiences problems. The next section focuses on MoCA-specific test requirements and how a service provider can quickly identify problems and reduce expensive customer visits and equipment replacement.

Supporting in-home MoCA networks

Support costs incurred as a result of quality and performance issues in the home will significantly affect the profitability and success of MoCA deployments. To win and retain customers, it is imperative that service providers get it right the first time. To do so in a MoCA environment requires traditional testing but also very new testing measures to verify that the in-home network can support the new services. The integrity of the in-home coax physical plant is the wildcard in the MoCA business case because of its unmanaged nature. This infrastructure has been outside the domain of service providers and is largely

installed by home builders, contractors, and in many cases, home owners. As a result, the service provider is compelled to support enhanced services in an unknown/uncertified environment.

There are significant implications for field teams and their managers.

Infrastructure

Will the existing in-home cable plant support MoCA throughput on all segments? Current service turn-up procedures typically involve rating the cable segments from the demarcation point to the STBs being installed. Since MoCA supports a full-mesh network between all nodes, procedures must be modified to rate all segments, not just from the initial splitter to outlets, but also STB-to-STB segments that may not include the initial splitter. Procedure changes should include validating throughput between all nodes in the home and not just from the initial splitter to each STB location. This must be done during service turn up, including qualifying all in-home devices during installation, but can also be done during maintenance visits to pre-qualify a customer for future services.

Spectrum

MoCA uses frequencies beyond the range of the typical signal level meter (SLM). To qualify an in-home network for MoCA, premises technicians must be armed with the tools required to conclusively validate a home network for MoCA-enabled services and perform troubleshooting during maintenance calls, as detailed in a later section.

Quality of experience

Since digital video is packet-based and the in-home network is managed via the MoCA network controller, the factors affecting QoE in a MoCA environment differ from those in traditional CATV installations. Training is required to prepare premises technicians to address customer expectations, educate the customer, and maximize customer QoE, not only for video quality, but also for interactions with all customer-facing elements of the service, including technicians.

Service support

Troubleshooting service problems now requires additional capabilities and expertise. The ability of front-line personnel to quickly and accurately pinpoint and correct the source of quality problems has a dramatic impact on product quality, support costs, customer satisfaction, and brand credibility.

Challenges

There are a number of challenges facing the field technician on a call with customer complaints in a MoCA network.

RF meter spectrum limitations

Because RF video and MoCA use separate frequency spectrums, it is possible for MoCA functionality and service to be affected even though RF video service is unaffected. To ensure the in-home network supports both MoCA and RF, proper measurements are required. Traditional RF meters in use today support frequencies in the 4–1000 MHz range. Because MoCA resides in the 850–1525 MHz range, traditional SLMs can only see a very small slice of the MoCA spectrum (the 150 MHz overlap). If the remaining MoCA frequency range is not verified, the service provider is rolling the dice on whether the enhanced services on the MoCA network will work.

Additionally, SLM measurements are typically taken from the point of ingress in the home to the various outlets throughout the home. This testing strategy does not assure that new services, such as multi-room DVR sharing, which routes from outlet to outlet, will function. To do so requires a much more comprehensive certification of the in-home network to ensure that all physical paths in the home meet the MoCA bandwidth requirements.

CPE statistics limitations

A STB or DVR provides limited statistics, such as connection speed or theoretical PHY throughput between nodes. However, these statistics are inadequate for the tester troubleshooting many in-home MoCA specific problems. PHY rates do not represent actual achievable rates for a link. CPE statistics will not alert the technician to problem segments that will not support MoCA rates. In addition, CPE statistics do not provide spectrum analysis or information on the service delivered over the connection, such as IP statistics. One could compare CPE statistics to the check engine light in a car, where there is an indication something is wrong but no details to help with the diagnosis and repair.

In addition, a STB or DVR is not portable. If the technician must go in the attic, basement, or crawl space to isolate the source of the problem, how will the STB be powered to provide statistics? More importantly, when troubleshooting a problem, the technician should not use as a test tool a device that may in fact be the source of the problem.

Identifying the problem source

Even if a specific problem is identified, such as attenuation in a specific frequency range, sectionalizing the in-home network to isolate the source can be problematic. Any number of components could be the cause, including a bad connector, improper splitter, out-of-range amplifier, filter, un-terminated cable run, noise interference, or the coax itself. The traditional tools available to field technicians are not suited for troubleshooting these issues in the MoCA spectrum. As a result, technicians are forced to make random changes in an attempt to clear the reported trouble.

Proper testing between MoCA node points with a certified MoCA tester enables the technician to rapidly sectionalize, isolate and identify the offending component. Tests are made before, after and through each component to verify its ability to support the MoCA spectrum. This precision testing eliminates random changes, certifies all devices and reduces overall technician repair time.

Swapping out components

Because of the lack of visibility into root causes for customer-reported issues, many technicians resort to swapping out equipment based on a best guess of the cause. As a result, tens of thousands of STBs and other devices are returned to suppliers each month for repair. Studies have shown that upwards of 85 percent of these returned STBs are found to be in perfect working order. The result of this strategy is the increased expense associated with a multiple dispatch and the unnecessary cost of re-certifying a perfectly good STB.

The fact that the original problem was never addressed, results in, increased customer dissatisfaction and gives a negative impression that the technician is not qualified to resolve the issue.

Troubleshooting

To assure customer acceptance and maximize the revenue potential of MoCA, the industry must bring to MoCA installations a set of tools appropriate to the technology and a best-practices methodology that

empowers front-line technicians to quickly and accurately identify and correct customer-reported problems.

Through the use of the following four-step troubleshooting process, technicians can progressively isolate and drill down to the root causes of MoCA-related service calls.

1. Assess the MoCA Network to determine the transmit and receive bandwidth between nodes.
2. Sectionalize individual nodes to validate proper operation of the MoCA interface.
3. Evaluate and certify the integrity of the links between the nodes.
4. Identify sources of interference on the MoCA spectrum.

Test	Description
Inter-node throughput test	Guarantee sufficient throughput between nodes to support MoCA services
CPE output test	Verify the output of a specific MoCA port to identify a faulty STB or DVR
Coax integrity test	Validate the ability of the physical plant to support MoCA services
Interference test	Isolate sources of interference that adversely affect throughput and MoCA operation

Table 2. MoCA troubleshooting tests

Inter-node throughput test

One of the objectives of MoCA is the guarantee of sufficient throughput to support DVR sharing, online gaming, residential business, and other high-bandwidth applications. MoCA 1.0/1.1 supports a PHY rate of 270 Mb/s.

The throughput capability of a MoCA network is not uniform throughout due to a variety of conditions. Variations in transmitter gains and receiver gains typically result in link asymmetry, where the capability of the forward path and reverse path differ. In addition, the effects of splitter jumping and reflections can result in significant differences in the channel characteristics in the link between nodes A and B, and the link between nodes A and C.

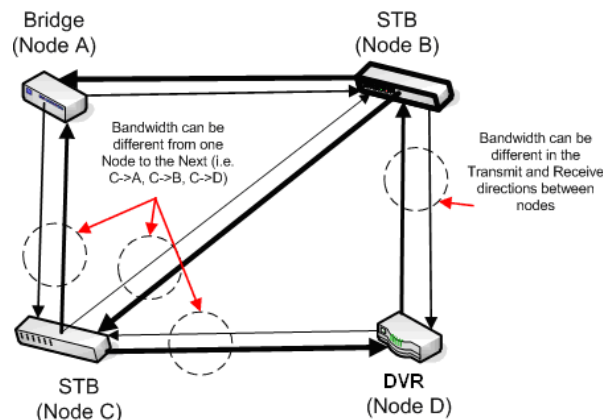

Line thickness represents bandwidth

Figure 4. Asymmetric MoCA bandwidth

The first step in troubleshooting is to assess the bandwidth, transmit and receive, between all nodes. Service providers should pre-determine the minimum amount of bandwidth required between nodes to support the services they offer. For example, a typical minimum bandwidth required to support DVR sharing might be 180 Mb/s.

Armed with this criterion the technician can easily determine if the path between nodes will support the service. To do so a technician joins the network with a MoCA tester and views the MoCA bandwidth table. This snapshot provides the technician with a clear understanding of the number of available nodes on the network and their available transmit and receive bandwidth. The bandwidth table highlights the links where insufficient bandwidth is available and where problems might occur. The technician can then limit efforts to address the specific nodes and node paths.

For example, if the bandwidth table indicates a deficiency between a DVR and a STB, the technician replaces one node with a MoCA tester and reviews the bandwidth table to verify that the minimum throughput is available between the test set and remaining node. This sectionalization/isolation methodology can be used throughout the MoCA network to pinpoint the precise location of the bandwidth-limiting fault.

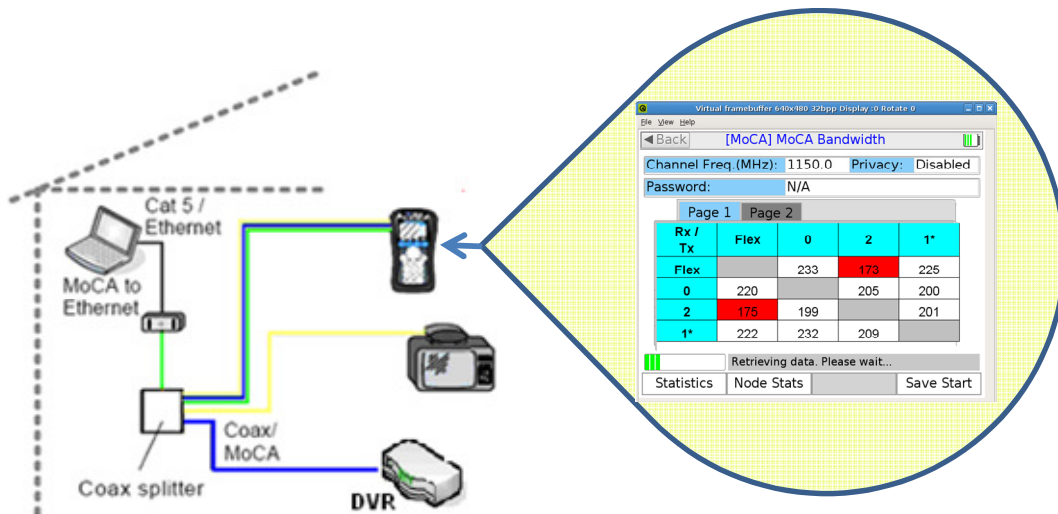

Figure 5. Inter-node throughput test

If a throughput issue is detected, the next step is to determine if a MoCA interface on one of the nodes is the source of the problem, and if so, on which node.

The inter-node throughput test also applies to pre-qualification testing. During the initial installation, the technician can perform in-home MoCA throughput prequalification to ensure the home network can support enhanced DVR sharing and other services, should the customer decide to upgrade later. This pre-qualification can enable a customer self-install and the service provider can be assured the service will operate without the need for an expensive site visit.

CPE output test

To determine which node has the defective interface, the technician connects a MoCA tester directly to the MoCA interface on one node (i.e. STB). The tester emulates the other node and interacts with the node under test to effectively create a two-node MoCA network (tester and STB). Then the technician tests the STB's MoCA interface without including in-home coax, splitters, etc. Under these conditions, the MoCA bandwidth between the STB and the tester should be approximately 250 Mb/s. If the bandwidth is significantly less, the STB should be considered defective. If the STB passes, the other node on the problematic link is tested in this fashion.

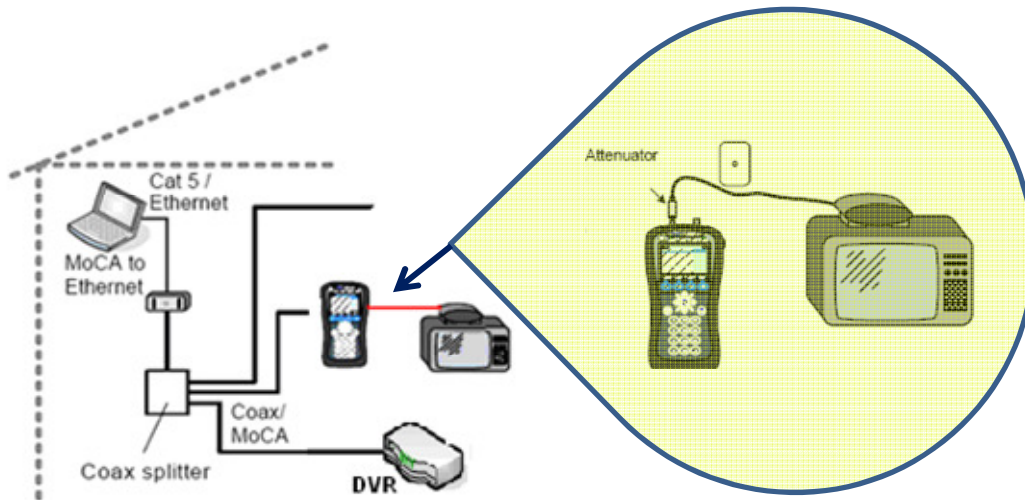

Figure 6. CPE output test

For example, in the case where the problematic link is between the DVR and a STB:

1. Test the STB.
 - a. Connect a MoCA tester directly to the MoCA interface on the STB.
 - b. Use the MoCA tester to emulate a DVR.
 - c. Measure the MoCA throughput.
 - d. If the result is less than 250 Mb/s, replace the STB.
2. Test the DVR.
 - a. Connect a MoCA tester directly to the MoCA interface on the DVR.
 - b. Use the MoCA tester to emulate a MoCA STB.
 - c. Measure the MoCA throughput.
 - d. If the result is less than 250 Mb/s, replace the DVR.

If both MoCA interfaces can transmit and receive 250 Mb/s, the devices do not need to be replaced. The next troubleshooting target is the in-home physical plant.

Coax integrity test

To check the integrity of the physical plant, the technician connects the MoCA tester to the STB's wall outlet and tests the bandwidth to all other MoCA nodes.

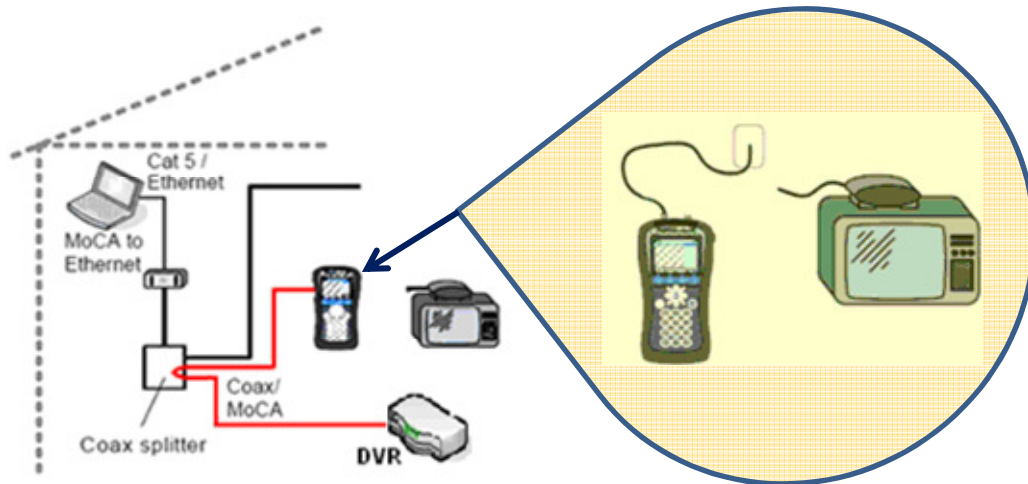

Figure 7. Coax integrity test

If a link has been sectionalized with throughput issues, the technician should physically inspect it for problems known to affect transmission:

- Too many, or wrong type, splitters or amplifiers
- An amplifier that doesn't support MoCA frequencies (most off-the-shelf amplifiers work up to 1 GHz)
- Un-terminated coax runs
- Poor crimping or other connector issues
- Nail through conductors or other conductor flaws
- Attenuation due to excessive cable length

If no problems are found in the physical plant, the final suspect is noise interference on the MoCA spectrum.

Interference test

Once testing has eliminated the node devices and the wiring, it's time to check for noise interference. To do this, a technician views the MoCA bit loading graph to determine the number of bits that subcarrier frequencies are carrying across the MoCA channel (7 bits maximum for 128-QAM). MoCA networks dynamically adjust the number of bits each subcarrier is expected to carry, loading each subcarrier to the maximum that probe exchanges have determined is feasible for reliable transmission. Therefore, a bit loading graph, which is essentially a granular view of channel bandwidth, displays all available subcarriers and the number of bits that each carries. The technician looks for a subcarrier frequency carrying less than 6 bits, which is an indication of noise interference on that frequency. (Note: The center frequency is always zero). Technicians can then attempt to locate and remove the source of interference. An improved bit loading graph will clearly show the interference has been removed, and improved bandwidth between the nodes should be evident.

By connecting a MoCA tester to the network and viewing the bit loading graph, technicians can see and remove interference. Without this visibility, the cause for low bandwidth due to frequency noise would be very difficult to determine.

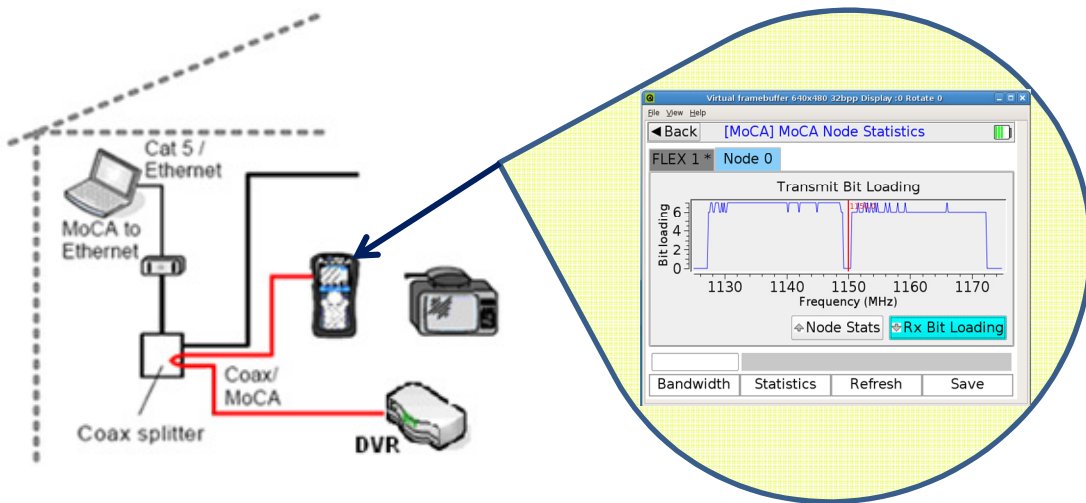

Figure 8. Interference test

Possible culprits include:

- Florescent lights
- Garage door opener
- Appliances

Service testing for DVR sharing

Multi-room DVR sharing is the main driver and a huge revenue potential for deploying a MoCA network. To provide a successful multi-room DVR-sharing MoCA network, the network from the DVR to any STB that will playback the video must be certified.

When a customer reports video quality issues, isolating the root cause can be difficult. Without a test set that can access the suspected segment, and give visibility into throughput and bit loading, a field technician must resort to trial and error, a time-consuming and inefficient method that increases support costs and customer frustration. As mentioned earlier, many of the MoCA in-home devices that are returned for repair are not defective and the potential cause of the problem is an intermittent or marginal operating MoCA network.

When faced with obvious quality issues, a technician needs to be able to pinpoint the source of the problem quickly and with confidence, whether it is the physical plant, CPE, or the customer's television set. Sending a technician on a trouble call without proper testing tools is neither efficient nor cost effective.

Troubleshooting steps for inline IPTV video testing

If the recommended four-step MoCA troubleshooting methodology described in the previous section shows an adequate MoCA network but the video problem persists, passive video quality testing can be used to identify conclusively whether quality problems are due to the video signal from the network. If not, the STB or the television is likely the cause of the problem.

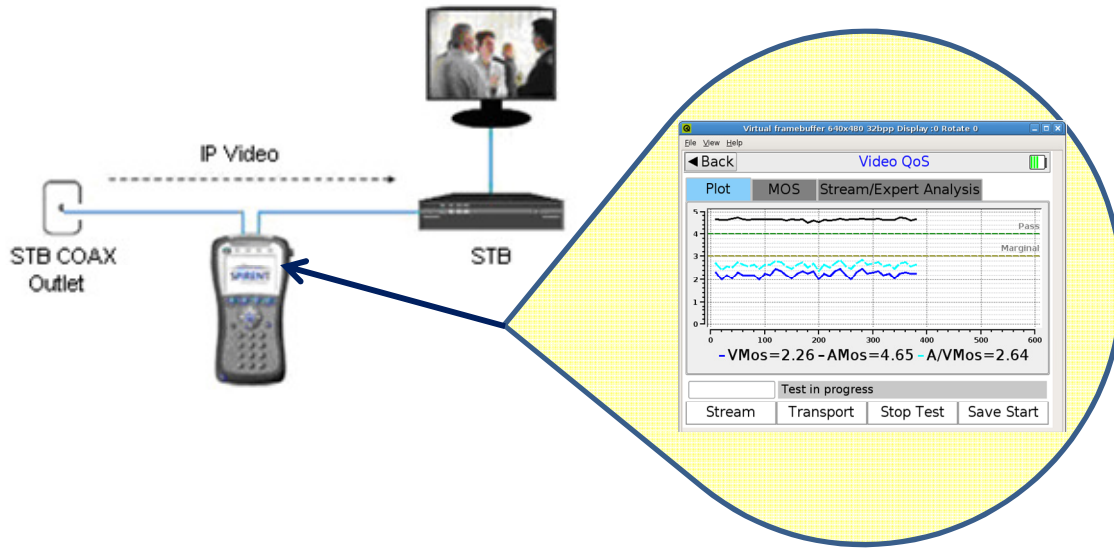

Figure 9. Passive video quality testing

To Perform Passive Video Quality testing the technician should:

Ensure MoCA is functional. Use the inter-node throughput test (See [Table 2](#) on page 15) to verify that the network delivers 180-230 Mb/s of throughput to the device in question.

Connect the tester for inline testing. Disconnect the coax cable from the STB and place the MoCA tester inline using two connectors on the tester to pass the video signal through to the STB.

Join the MoCA network passively. Tester joins the MoCA network on the A and B ports by selecting the appropriate frequency for both sides of the connection. In this configuration the tester joins the network in passive mode.

Report the video quality. While the tester is in passive mode, the video stream passes through the tester to the STB destination. The MoCA tester evaluates the video signal as it passes through and reports critical metrics that indicate the quality of the signal delivered to the STB. One of the key metrics reported is a Video Mean Opinion Score (V-MOS), an objective method of measuring video quality. V-MOS is represented as a number between 1 (bad) and 5 (good).

While the technician monitors the V-MOS on the test set, the TV displays the video. If the TV displays poor video but the V-MOS score is in the good range, the problem is either the STB or TV. If the V-MOS shows a bad or poor score, the STB and TV are good and the problem is coming from the network.

If the problem is due to the signal, the V-MOS score will drop at the same time that the quality issues appear on the screen. If the problem persists with no corresponding indication in the metrics, the network up to the point of the tester is not the source of the problem.

If the tester indicates problems with the signal, the technician can isolate the issue to a specific MoCA network segment, including the segment from the provider to the line of demarcation. In that case, the field technician can report hard metrics rather than mere symptoms to the MSO for further troubleshooting.

This objective measurement method leaves little doubt about the source of the problem. Compare this to a subjective measurement, such as simply viewing the TV, and one can see the obvious advantages of passive video quality testing.

Various metrics for assessing quality include the percent of degradation from the codec, packet loss, delay and jitter. These measurements can provide valuable insight for Tier II technicians pursuing network trouble.

Conclusion

Service providers are experiencing huge take-rates in the delivery of advanced IP and multimedia services, opening new channels for revenue. MoCA is the in-home distribution technology that leverages existing coax cable networks prevalent in over 90 percent of US homes. MoCA is attractive because it provides a relatively low-cost method of getting DVR and other multimedia sharing video services to multiple TVs within the home without expensive and time-consuming cable installation. However, MoCA only benefits the service provider if the home coax wiring supports the MoCA spectrum, which extends beyond the current CATV spectrum of 1 GHz.

The challenge is the in-home network itself and the ability of the field force to support this new technology. Range, amplifiers, splitters, poor connections, bad cable, and wideband interference must be validated and any trouble diagnosed and corrected before service can be established and guaranteed. In addition, without sufficient data throughput between nodes, services such as multi-room DVR can be severely affected, resulting in less than acceptable video. This means providers will have to dispatch technicians who must be prepared and equipped to qualify and troubleshoot MoCA related problems within the home network.

A coax-wired home that currently supports broadcast video services may not support up-selling DVR sharing or other enhanced video services. A potential solution is to pre-qualify the home coax network during service turn up or maintenance visits. Providers who can quickly adapt their tools and services for the rapidly changing in-home network will have the advantage in quality, credibility, customer satisfaction, operational efficiencies, and ultimately, revenue.



Bibliography

Deans, David H. "Video-Enabled Home Network Node Growth." *Digital Lifescapes*. Mar. 20, 2009
<http://dhdeans.blogspot.com/2009/03/video-enabled-home-network-node-growth.html>

"Wi-Fi, MoCA, HPNA, and HomePlug - who will win?" Oct. 24, 2006
<http://www.tvover.net/2006/10/24/WiFi+MoCA+HPNA+And+HomePlug+Who+Will+Win.aspx>

Appendix A: Troubleshooting Guide

Process Flow = “Verifying In Home MoCA Bandwidth is sufficient for DVR Sharing”

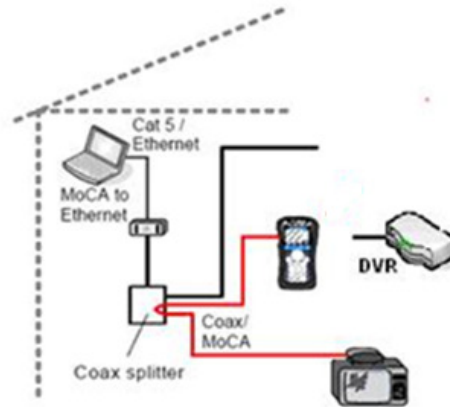
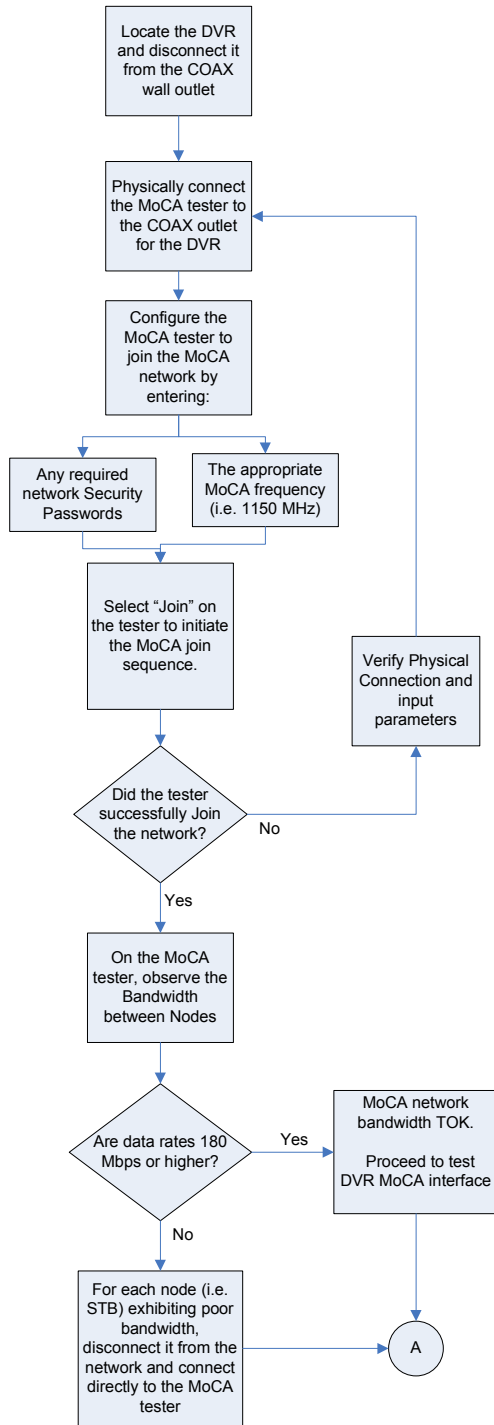

Process Flow = “Verifying the In Home CPE’s (DVR, STB)
MoCA Interface Bandwidth is sufficient for DVR Sharing”

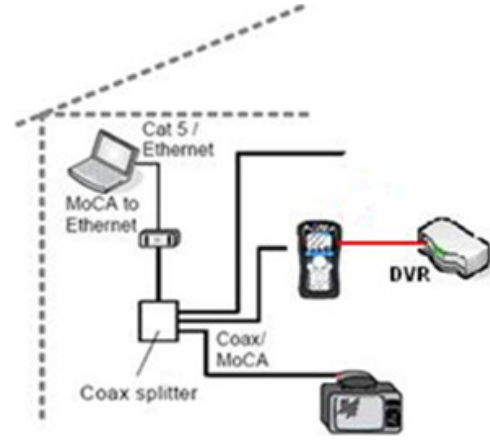
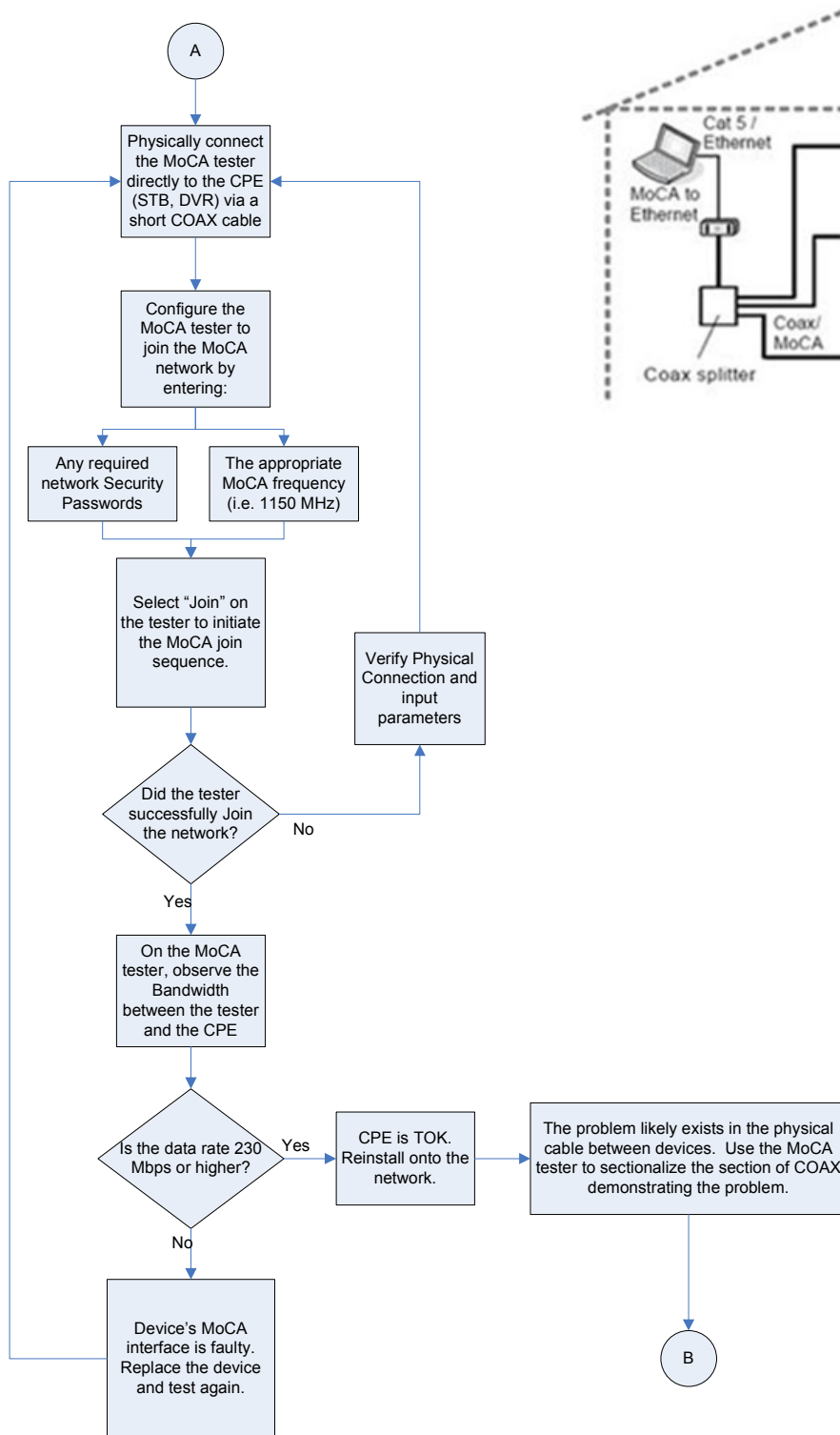

Process Flow = “Verifying the In Home physical plant’s ability to support the MoCA Bandwidth required for DVR Sharing”

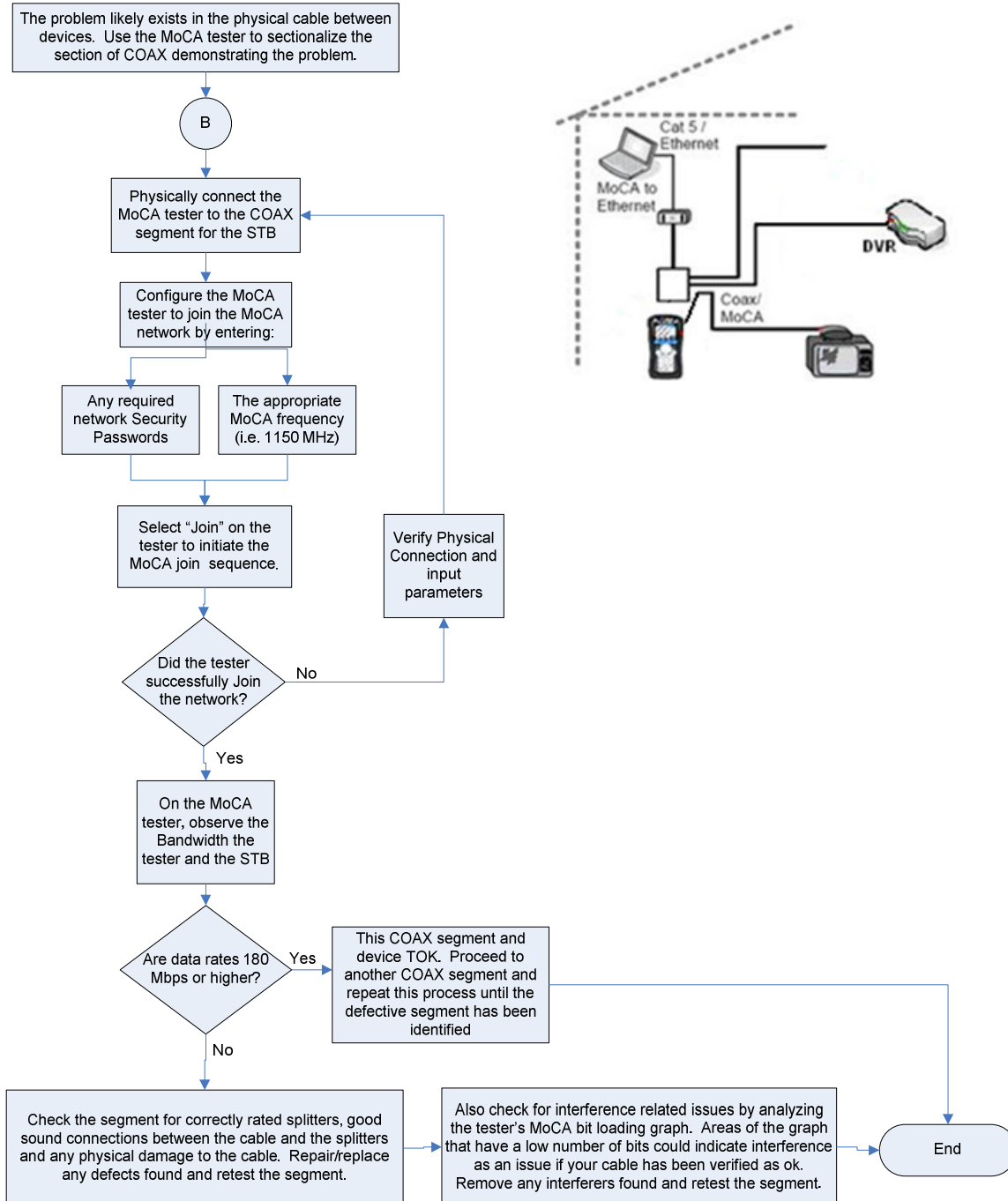

Appendix B: Acronyms

ACMT	Adaptive Constellation Multi-Tone
AES	Advanced Encryption Standard
BPSK	Binary Phase Shift Keying
CAT5/6	Category 5/6
CATV	Cable Television
CDMA/CD	Code Division Multiple Access with Collision Detection
CEPCA	Consumer Electronics Powerline Communication Alliance
CPE	Customer Premises Equipment
DBPSK	Differential Binary Phase Shift Keying
DES	Digital Encryption Standard
DLNA	Digital Living Network Alliance
DBPSK	Differential Binary Phase Shift Keying
DQPSK	Differential Quadrature Phase Shift Keying
DVR	Digital Video Recorder
FEC	Forward Error Correction
Gb/s	Gigabit per Second
GHz	Gigahertz
IEEE	Institute of Electrical and Electronics Engineers
HomePNA™	Home Phoneline Networking Alliance
HPNA	Home Phoneline Networking Alliance
IP	Internet Protocol
IPTV	Internet Protocol Television
ITU-T	International Telecommunication Union - Telecommunication Standardization Sector

kb/s	Kilobits per Second
kHz	Kilohertz
LAN	Local Area Network
MAC	Media Access Control
Mb/s	Megabits per Second
MHz	Megahertz
MIMO	Multiple Input Multiple Output
MoCA	Multimedia over Coax Alliance
MSO	Multiple System Operator
NC	Network Controller
OCAP	OpenCable™ Application Platform
OFDM	Orthogonal Frequency Division Multiplexing
PHY	Physical (layer)
QAM	Quadrature Amplitude Modulation
QoE	Quality of Experience
QoS	Quality of Service
QPSK	Quadrature Phase Shift Keying
RF	Radio Frequency
SLM	Signal Level Meter
STB	Set-Top Box
TDMA	Time Division Multiple Access
TOK	Test OK
UPA	Universal Powerline Association
V-MOS	Video Mean Opinion Score
VDSL	Very High-bit-rate Digital Subscriber Line



VoIP	Voice over Internet Protocol
WAN	Wide Area Network
WiFi	Wireless Fidelity



Contact Information

SCTE

For additional information on this topic, please contact the authoring company directly through the contact information provided below. Comments on Implication Papers in general can be directed to ImplicationPaper@scte.org.

Spirent Communications

Bill Belt is a veteran of the communications industry who, in his 35 year career, has held a variety of positions in Field Operations, Remote Test & Diagnostic Systems management and Field Test Product Management in the MSO and Telco markets. This wide array of experience has provided him insight on the critical tools and processes necessary for ensuring an exceptional Quality of Experience (QoE), to the subscriber. Bill, a member of the Piedmont Chapter of the SCTE, is currently with Spirent Communications where he is the Product Manager responsible for Field Test Solutions. His responsibilities include product planning and execution throughout the product lifecycle, including: gathering and prioritizing product and customer requirements, defining the product vision, and working closely with engineering, sales, marketing and support to ensure product and customer satisfaction goals are met. Bill can be reached at bill.belt@spirent.com or 301-444-2490.

Ron Hammond is a communications veteran with over 25 years experience working with cable and telco. His career started at Hekimian Laboratories in Rockville MD where he was a systems engineer responsible for solution testing and field trial management for the portable and system product line. He is currently Director of Product Management at Spirent Communications and is responsible for the field test and remote monitoring and diagnostic product solutions. Spirent is a world leader in innovative solutions for Cable and Telco from the lab to the live environment. Ron can be reached at ron.hammond@spirent.com and 301-444-2414.